

## Datasheet :- LMCX300M



### Description

- Slimline monitored magnetic lock.
- Surface mounted.
- Dual voltage
- Silver with anodised aluminium
- Up to 300kg holding force<sup>ck</sup>

### Application

Medium security applications for internal and external doors. To be mounted on the inside of an external door.

### Technical Information

Model	LMCX300M
Input voltage	12/24V
Current consumption (quiescent)	440mA (+/- 2.5%@13.5v)
Holding force	241kgs (530lb) at 12v 329kgs (723lb) at 24v
Lock size (L)	250mm
Lock size (H)	47mm
Lock size (W)	26mm
Magnetic bond sensor	yes
Bi colour LED.	Yes
Door status switch	No
Monitored	Yes
Mounting	surface
Z & L Bracket	LMCX300ZL

## Installation Drawings

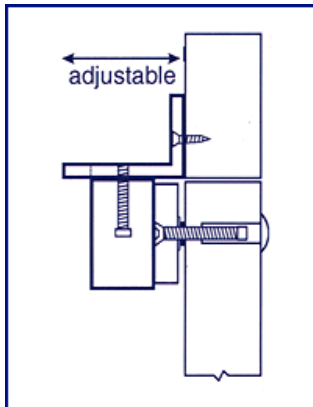

L Bracket Installation  
Outward door installation

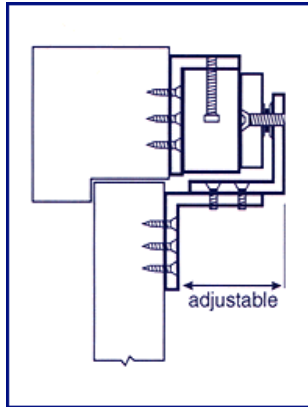

Z Bracket Installation  
Inward door installation